

**RELAXATION IN HIGH-STRENGTH BOLTED
CONNECTIONS WITH GALVANIZED STEEL**

John T. DeWolf, Professor
Jun Yang, Graduate Research Assistant

Final Report
May, 1998

JHR 98-262

Project 96-4

This research was sponsored by the Joint Highway Research Advisory Council (JHRAC) of the University of Connecticut and the Connecticut Department of Transportation and was carried out in the Civil and Environmental Department of the University of Connecticut.

The contents of this report reflect the views of the author(s) who are responsible for the facts and accuracy of the data presented herein. The contents do not necessarily reflect the official views or policies of the University of Connecticut or the Connecticut Department of Transportation. This report does not constitute a standard, specification, or regulation.

Technical Report Documentation Page

1. Report No. JHR 98-262		2. Government Accession No.		3. Recipient's Catalog No.	
4. Title and Subtitle Relaxation in High-Strength Bolted Connections with Galvanized Steel				5. Report Date 5/11/98	
				6. Performing Organization Code	
7. Author(s) John T. DeWolf and Jun Yang				8. Performing Organization Report No. Project 96-4	
9. Performing Organization Name and Address University of Connecticut Department of Civil and Environmental Engineering 191 Auditorium Road, Box U-37 Storrs, CT 06269				10. Work Unit No. (TRAIS)	
				11. Contract or Grant No.	
12. Sponsoring Agency Name and Address Connecticut Department of Transportation 280 West Street Rocky Hill, CT 06067-0207				13. Type of Report and Period Covered Final Report	
				14. Sponsoring Agency Code	
15. Supplementary Notes					
16. Abstract <p>In recent bridge construction in Connecticut, significant relaxation was found in high-strength bolted connections with galvanized plates, where the coating thickness was approximately 13 mils. There was concern that this could result in a significant reduction in shear capacity. The current AASHTO Specification is based on research conducted with coating thicknesses not greater than 6 mils. In this research, tests were conducted to study the relaxation and shear capacity of the high-strength bolted connections with galvanized coating thicknesses ranging to 20 mils. Both normal and oversized holes were studied. The amount of relaxation associated with the coating thickness was determined experimentally. The shear capacity of the connections with the thicker coating reduced due to the loss in clamping force. The test results have been used to develop design guidelines.</p>					
17. Key Words Bolted Connections, Bridge Design, Connections, Creep Behavior, Galvanizing, Relaxation, Structural Steel, Testing				18. Distribution Statement	
19. Security Classif. (of this report)		20. Security Classif. (of this page)		21. No. of Pages 46	22. Price

SI* (MODERN METRIC) CONVERSION FACTORS

APPROXIMATE CONVERSIONS TO SI UNITS

APPROXIMATE CONVERSIONS TO SI UNITS

Symbol	When You Know	Multiply By	To Find	Symbol	When You Know	Multiply By	To Find	Symbol
--------	---------------	-------------	---------	--------	---------------	-------------	---------	--------

LENGTH

in	inches	25.4	millimetres	mm	millimetres	0.039	inches	in
ft	feet	0.305	metres	m	metres	3.28	feet	ft
yd	yards	0.914	metres	m	metres	1.09	yards	yd
mi	miles	1.61	kilometres	km	kilometres	0.621	miles	mi

AREA

in ²	square inches	645.2	millimetres squared	mm ²	millimetres squared	0.0016	square inches	in ²
ft ²	square feet	0.093	metres squared	m ²	metres squared	10.764	square feet	ft ²
yd ²	square yards	0.836	metres squared	m ²	hectares	2.47	acres	ac
ac	acres	0.405	hectares	ha	kilometres squared	0.386	square miles	mi ²
mi ²	square miles	2.59	kilometres squared	km ²				

VOLUME

fl oz	fluid ounces	29.57	millilitres	mL	millilitres	0.034	fluid ounces	fl oz
gal	gallons	3.785	Litres	L	litres	0.264	gallons	gal
ft ³	cubic feet	0.028	metres cubed	m ³	metres cubed	35.315	cubic feet	ft ³
yd ³	cubic yards	0.765	metres cubed	m ³	metres cubed	1.308	cubic yards	yd ³

NOTE: Volumes greater than 1000 L shall be shown in m³

MASS

oz	ounces	28.35	grams	g	grams	0.035	ounces	oz
lb	pounds	0.454	kilograms	kg	kilograms	2.205	pounds	lb
T	short tons (2000 lb)	0.907	megagrams	Mg	megagrams	1.102	short tons (2000 lb)	T

TEMPERATURE (exact)

°F	Fahrenheit temperature	5(F-32)/9	Celcius temperature	°C	Celcius temperature	1.8C+32	Fahrenheit temperature	°F
----	------------------------	-----------	---------------------	----	---------------------	---------	------------------------	----

LENGTH

mm	millimetres	0.039	inches	in
m	metres	3.28	feet	ft
m	metres	1.09	yards	yd
km	kilometres	0.621	miles	mi

AREA

mm ²	millimetres squared	0.0016	square inches	in ²
m ²	metres squared	10.764	square feet	ft ²
ha	hectares	2.47	acres	ac
km ²	kilometres squared	0.386	square miles	mi ²

VOLUME

mL	millilitres	0.034	fluid ounces	fl oz
L	litres	0.264	gallons	gal
m ³	metres cubed	35.315	cubic feet	ft ³
m ³	metres cubed	1.308	cubic yards	yd ³

MASS

g	grams	0.035	ounces	oz
kg	kilograms	2.205	pounds	lb
Mg	megagrams	1.102	short tons (2000 lb)	T

TEMPERATURE (exact)

°C	Celcius temperature	1.8C+32	Fahrenheit temperature	°F
----	---------------------	---------	------------------------	----

°F	32	98.6	212
°C	-40	0	40
°C	80	120	180
°C	200		
°C	37	40	60
°C	100	80	100

* SI is the symbol for the International System of Measurement

ACKNOWLEDGMENTS

The work presented in this paper was supported under the Joint Highway Research Program funded by Connecticut Department of Transportation. Valuable input during many phases of research was provided by Mr. Michael Culmo of the ConnDOT Bridge Design Unit. Special thanks are given to Mr. E. Troup of Structural Steel Fabricators of New England, Canton, MA, for assistance in obtaining the test specimens. The assistance from Mr. J. Vidmar of National Eastern Corporation, Plainville, CT, in supplying plates and bolts is acknowledged. In achieving galvanized coatings, the assistance by J. Danca and D. Klohn of Duncan Galvanizing Company, Everett, MA, is greatly appreciated. Thanks are also given to Mr. David Strever of the Division of Materials Testing of the Connecticut Department of Transportation for his technical support. The congenial technical assistance of Mr. Robert Balfe, Tommaso Marcellino, Serge Doyon and Richard Bonnaza of the Machine Shop, University of Connecticut, is gratefully acknowledged.

TABLE OF CONTENTS

Technical Report Documentation	ii
Metric Convension	iii
Acknowledgments	iv
Table of Contents	v
List of Figures	vii
List of Tables	viii
Introduction	1
Test Program	1
Preparation of Specimens	3
Slip Coefficient Tests	4
Bolt Tensile Clamping Force	5
Test Setup	6
Relaxation and Creep Tests	6
Relaxation Tests	6
Creep Tests	6
Test Results	9
Slip Coefficient Tests	9
Clean Mill Scale Surfaces	13
Galvanized Surfaces	13
Hole Size Effect	14

Relaxation Of Clamping Force	15
Relaxation Tests	18
Creep Behavior	20
Design Recommendations	26
Conclusions	27
References	28
Appendix	30

LIST OF FIGURES

Figure 1.	Test Specimen for Slip Coefficient Test	5
Figure 2.	Creep Specimens in Chain	8
Figure 3.	Slip Measurement	9
Figure 4.	Definition of Slip Load	11
Figure 5.	Test Curve of Load vs. Slip for Galvanized Surfaces	11
Figure 6.	Slip Coefficient vs. Coating Thickness	14
Figure 7.	Typical Stress Relaxation Curves	17
Figure 8.	Stress Losses vs. Coating Thickness	17
Figure 9.	Creep Behavior for Plain Steel	21
Figure 10.	Creep Behavior for Galvanized Surfaces with 5-mil Thick Coating	22
Figure 11.	Creep Behavior for Galvanized Surfaces with 10-mil Thick Coating	23
Figure 12.	Creep Behavior for Galvanized Surfaces with 15-mil Thick Coating	24
Figure 13.	Creep Behavior for Galvanized Surfaces with 20-mil Thick Coating	25

LIST OF TABLES

Table 1.	Planned Slip Coefficient Tests	2
Table 2.	Planned Relaxation and Creep Tests	3
Table 3.	Actual Coating Thicknesses	4
Table 4.	Test Results of Slip Coefficient	12
Table 5.	Relaxation of Clamping Force	16
Table 6.	Comparison of Slip Load with and without Relaxation	19
Table Appendix 1.	Slip Coefficient Test Results	30
Table Appendix 2.	Test Results for Creep Tests	32

Technical Report Documentation Page

1. Report No. JHR 98-262		2. Government Accession No.		3. Recipient's Catalog No.	
4. Title and Subtitle Relaxation in High-Strength Bolted Connections with Galvanized Steel				5. Report Date 5/11/98	
				6. Performing Organization Code	
7. Author(s) John T. DeWolf and Jun Yang				8. Performing Organization Report No. Project 96-4	
9. Performing Organization Name and Address University of Connecticut Department of Civil and Environmental Engineering 191 Auditorium Road, Box U-37 Storrs, CT 06269				10. Work Unit No. (TRAIS)	
				11. Contract or Grant No.	
				13. Type of Report and Period Covered Final Report	
12. Sponsoring Agency Name and Address Connecticut Department of Transportation 280 West Street Rocky Hill, CT 06067-0207				14. Sponsoring Agency Code	
15. Supplementary Notes					
16. Abstract In recent bridge construction in Connecticut, significant relaxation was found in high-strength bolted connections with galvanized plates, where the coating thickness was approximately 13 mils. There was concern that this could result in a significant reduction in shear capacity. The current AASHTO Specification is based on research conducted with coating thicknesses not greater than 6 mils. In this research, tests were conducted to study the relaxation and shear capacity of the high-strength bolted connections with galvanized coating thicknesses ranging to 20 mils. Both normal and oversized holes were studied. The amount of relaxation associated with the coating thickness was determined experimentally. The shear capacity of the connections with the thicker coating reduced due to the loss in clamping force. The test results have been used to develop design guidelines.					
17. Key Words Bolted Connections, Bridge Design, Connections, Creep Behavior, Galvanizing, Relaxation, Structural Steel, Testing				18. Distribution Statement	
19. Security Classif. (of this report)		20. Security Classif. (of this page)		21. No. of Pages 46	22. Price

INTRODUCTION

Galvanizing has been used on bridges to provide corrosion protection for more than 20 years. Normally, the coating thickness varies depending on the application equipment and process. Currently, there are no design specifications which limit the coating thickness. Previous research studies were based on thicknesses no larger than 6 mils [6]. These tests were used to develop the provisions of the American Association of State Highway and Transportation Officials (AASHTO) [1].

Variability in thickness of the metallic layer is inherent with the galvanizing process. The thickness is influenced by both the time the steel member is immersed in the zinc bath tank and the tank temperature. Also, zinc build-up on lower end of member will affect the coating thickness when the item is removed from the bath. In addition, thicker plates result in a larger coating thickness. Thus it is possible to get thickness significantly larger than 6 mils.

When the coating is not thick (within 6 mils), the relaxation of clamping force of a bolted connection due to the creep of the soft zinc layer is not severe. However, recent applications of galvanized coatings for bridges in Connecticut have produced coating thicknesses up to 13 mils. This caused concern that there might be a large loss in the connection clamping force. The result would be a corresponding reduction in the shear capacity of the bolted connection.

It has been the purpose of this study to determine the influence of thicker galvanized coatings on the shear resistance in bolted connections. The research involved an experimental program for high-strength bolted connections with coating thicknesses from 0 to 20 mils. This was done for both standard and oversize holes. Two test sets were conducted, one to determine the slip coefficient and one to determine the relaxation and creep effects.

TEST PROGRAM

The following test program was developed to: a) determine the slip coefficient of the coatings under short-term static loading; and, b) determine the loss of clamping force and the reduction of slip resistance under long-term sustained loading. This involved three sets of tests: 1) slip coefficient tests to determine the short-term shear capacity; 2) relaxation tests to determine the amount of bolt relaxation over time; and, 3) creep tests to determine the slip resistance under long-term loading.

The main goal was to determine the shear capacity of the connections and to evaluate the relaxation of clamping force under service loading. The design of the experimental program was based on the testing method recommended by the American

Institute of Steel Construction (AISC) [14].

The experimental work included a total of 58 specimens, with 30 for the slip coefficient test and 28 for relaxation and creep tests. The specimen variables were:

- 1). Galvanizing Thickness: from 0 to 20 mils.
- 2). Hole Size: for 7/8 in. A325 bolts, standard hole diameter $D=15/16$ in., oversize hole diameter $D=1-1/8$ in.; and,
- 3). Clamping Force: 39 kips based on the "Standard Testing Method for Determining the Slip Coefficient" [13], for 7/8 in. Diameter A325 bolts (AASHTO M164 bolts).

At first, all specimen plates were designed to be 7/8 inches thick. The galvanizing fabricator said that the plates must be at least 1 inch thick, to get the coating thicknesses up to 20 mils. Therefore, all specimens were fabricated from 1 inch thick A588 weathering steel plate.

Table 1. Planned Slip Coefficient Tests

Galvanized Coating Thickness (mils)	Standard Holes (Diameter= $15/16$ in.)	Oversize Hole (Diameter= $1-1/8$ in.)
0	3	3
5	3	3
10	3	3
15	3	3
20	3	3

No. of Tests = 3 x 5 (thicknesses) x 2 (hole size) = 30

Table 2. Planned Relaxation and Creep Tests

Galvanized Coating Thickness (mils)	Standard Holes (Diameter=15/16 in.) (Relaxation Tests only)	Oversize Hole (Diameter=1-1/8 in.) (Creep Tests only)
0	3	3
5	2	2
10	3	3
15	3	3
20	3	3

No. of Tests = 3 x 4 (thicknesses) x 2 (hole sizes) + 4 = 28

Preparation of Specimens

The specimens were fabricated in a machine shop and then sent for galvanizing. The hot-dip galvanizing process generally begins with the removal of the mill scale on the item prior to the coating application. This is done by pickling the member in a bath of acid to remove mill scale and rust. The item is then rinsed, fluxed and immersed in the molten zinc until it comes up to the bath temperature. The iron in the item then reacts with the zinc liquid to form several iron-zinc alloy layers. These alloy layers are covered with a layer of pure zinc. The zinc and alloy layers together provide a protective barrier to the steel.

The galvanized coating was applied according to "Standard Specification for Zinc (hot-dip galvanized) Coatings on Iron and Steel Products", which was approved by American Society for Testing and Materials (ASTM) in September, 1989, and known as ASTM A123 (AASHTO M111).

A Mikrotest gage was used to measure the coating thickness. It is a nondestructive magnetic gage which can measure nonmagnetic coatings on ferrous elements. Normally, eight readings were taken for each plate (four on each side). These readings were recorded and were the basis for selecting plate contact surfaces. The sides selected for the contact surfaces had the smallest variation in coating thickness and an average thickness closest to the desired thickness. Table 3 lists the actual coating thicknesses for the test specimens. More details are included in reference 13.

Table 3. Actual Coating Thicknesses

Nominal Coating Thickness (mils)	Range of Thickness (mils)	Average Thickness (mils)	Standard Deviation
5	5.0 - 5.6	5.2	0.2
10	11.7 - 13.8	12.7	0.8
15	14.6 - 17.5	16.1	0.9
20	18.3 - 20.4	19.7	0.5

NOTE: The galvanizing process did not produce any specimens with 10-mil thicknesses. The test specimens had thickness greater than 10 mils as shown in the table. The specimens in the 11.7 to 13.8 mils range were used in the creep and relaxation tests only.

Slip Coefficient Tests

The slip coefficient test is a static, short-term test. The goal is to evaluate the slip coefficient for varying coating thickness. This is the test used to determine the shear capacities. The test design was based on the American Institute of Steel Construction (AISC) recommendations [14].

The test specimens have a double lap joint with a single hole. This is shown in Figure 1. Each specimen consisted of three identical plates which were bolted together with a galvanized, high-strength, 7/8 in. ASTM A325 bolt and galvanized washers [12]. The total clearance in the hole was either 1/16 inch for standard hole sizes or 1/4 inch for oversize hole sizes. The plates were fabricated from A588 weathering steel which is commonly used for steel bridges in Connecticut. The galvanized surfaces were roughened by hand wire brushing prior to assembly according to the specification requirement (AASHTO) [1]. The wire brushing did not reduce the overall coating thickness.

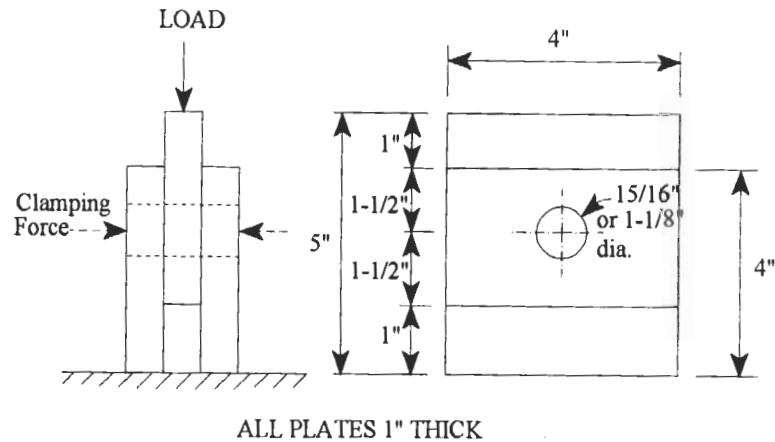

Figure 1. Test Specimen for Slip Coefficient Test

Bolt Tensile Clamping Force

Variations in the clamping force were minimized to reduce scatter in the test results. Previous researchers have used either the bolt calibration method or a hydraulic jack device to control the bolt force [7, 10, 14, 15]. In the bolt calibration method, a load indicating device called Skidmore Wilhelm is needed to develop a relationship between the bolt tension and the elongation of the bolt. This can then be used to determine the actual bolt tension force, or clamping force. In the second approach [10, 15], the clamping force is applied by means of a high-strength steel rod acting with a center-hole hydraulic jack. A load cell is usually used to determine the clamping force. The clamping force thus provides the equivalent clamping effect as would be provided from a high-strength bolt.

An additional way to provide the required clamping force is recommended by "Testing Method to Determine the Slip Coefficient for Coatings Used in Bolted Joints", American Institute of Steel Construction(AISC) [14]. This approach uses bolts with strain gages. It was the most accurate way to measure the bolt tension [2]. The resulting tensile bolt force has been reported to be within 2% of the required values [2, 5]. The strain-gaged bolts were used in this research. Based on the recommendation of American Institute of Steel Construction (AISC) [14], the bolt tension force for the 7/8" A325 bolt should be 39 kips. This was achieved in all tests.

Two strain gages were placed on each of two small flat surfaces which were milled

on each side of the bolt shank. The surfaces were sanded, and the strain gages were applied with a microspot welder. Two 0.089-inch holes were drilled in the bolt head for the gage's three wires. A strain gage data acquisition system, developed by OPTIM, was used to collect data.

Test Setup

The tests were carried out in a 60-kip SATEC hydraulic test machine. An electronic x-y plotter was used to plot the load versus slip. Two dial gages were used to verify the amount of slippage.

Relaxation and Creep Tests

Previous research has indicated that relaxation in the bolt is related to the thickness of the coating. It is expected that more relaxation will occur with thicker coating. This results in a larger decrease in shear capacity. Previous studies also found that the behavior under sustained loads for long periods may differ from the short-time loading performance [10]. A study conducted by the Propulsion Laboratory in Pasadena, CA [8] pointed out that all of the coating systems exhibited a steady state rate of slip for the duration of the tests, once movement was initiated. Field experience and tests results also have indicated that galvanized members have a tendency to continue to slip under sustained loading [6]. Thus, this set of tests was designed to achieve the following goals:

- a) Determine the creep behavior;
- b) Determine how the slip resistance is affected by the coating thickness; and,
- c) Establish design recommendations based on the coating thickness.

With modifications based on previous research, two sets of tests were carried out, one to measure the relaxation directly and one to determine the creep behavior.

Relaxation Tests

A total of 14 tests were carried out. Each specimen consisted of three plates, each 4 in. x 4 in. x 1 in. with a standard hole as shown in Figure 1. The same setup used for the slip coefficient test was used for these tests. The specimens were tested in shear 21 days after assembly to determine if the slip resistance was altered. There was no shear loading during this 21-day period. Six specimens with clean-mill scale surfaces were included to provide for comparisons with the different coating thicknesses.

Creep Tests

In the creep tests, 1-1/8 inch diameter oversize holes were used to ensure that adequate hole clearance would be available for slippage. The assembly was carefully made to ensure the bolts were positioned in the holes so that the load was not initially transferred by bearing. The specimens were made from A588 steel bar stock. Each

specimen consisted of three plates each 7 in. x 4 in. x 1 in. as shown in Figure 2. These dimensions were selected to match the width and thickness of the static compression slip tests, and also allow the specimens to be connected in series as a chain.

The test specimens were connected in a chain as shown in Figure 2. The top bolt in each set was tightened to the desired clamping force of 39 kips, the lower pin bolt was only hand-tightened.

The individual specimens were initially bolted together utilizing a hand wrench and then linked together to form the chain. The chain consisted of 14 specimens, three with clean-mill scale surfaces, two with coating 5 mils thick, three with coating 10 mils thick, three with coating 15 mils thick, and three with coating 20 mils thick. All of these were then subjected to the same tensile loading. The chain method was used to double the number of specimens per test to get an average slip measurement for each coating thickness.

Two measurement pieces were welded to each specimen set prior to assembly of the chain. These pieces consisted of two short pieces of 1/8 in. x 3/4 in. x 3/4 in. steel angle. They were attached to each side of the specimen to monitor the creep information over time as shown in Figure 3. Measurements were taken using a micrometer. The amount of slip was taken as the average of the two gages on each specimen. The stress relaxation in the bolt was collected with the strain-gage monitoring system.

The test chain was subjected to a service loading condition of 20.8 kip, which was determined based on current AASHTO Specification for 7/8" A325 high-strength bolts. The test load was applied for a 42-day period according to recommendation of Yura [15].

Temperature compensation was provided for the strain gage readings. This was done by connecting an unloaded bolt to the monitoring system to correct for any temperature changes.

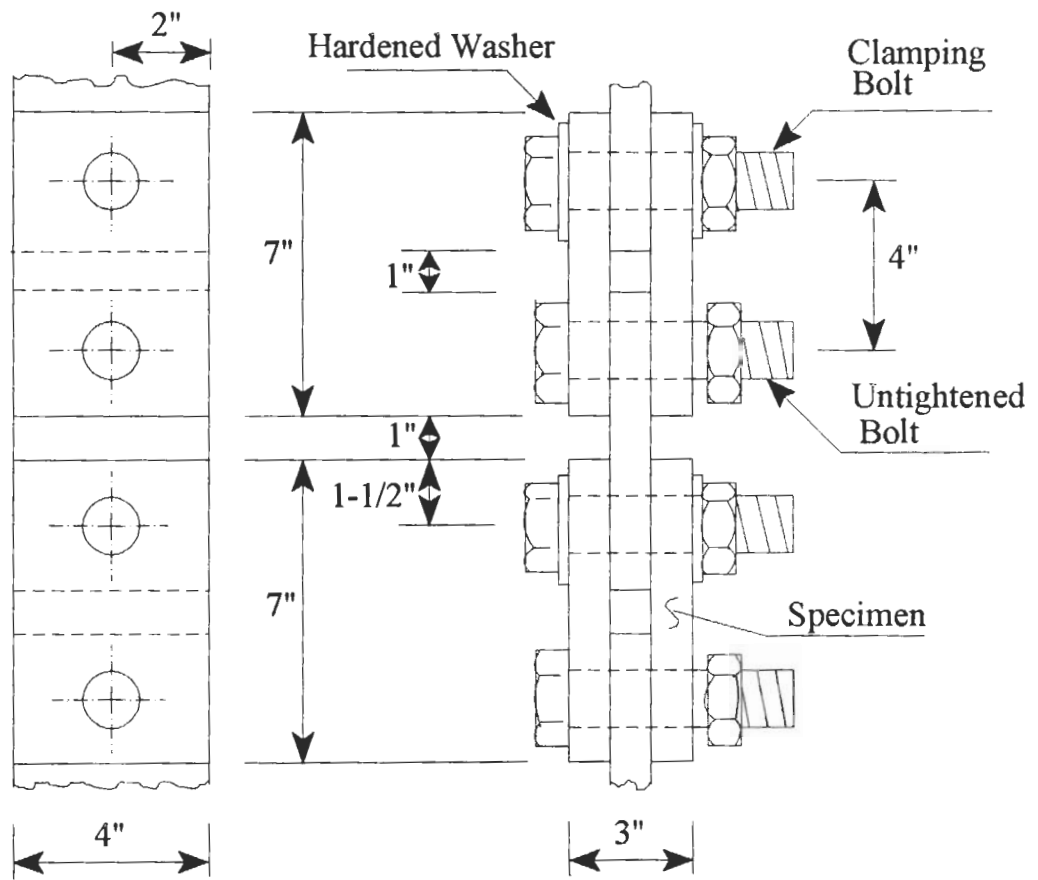

Figure 2. Creep Specimens in Chain

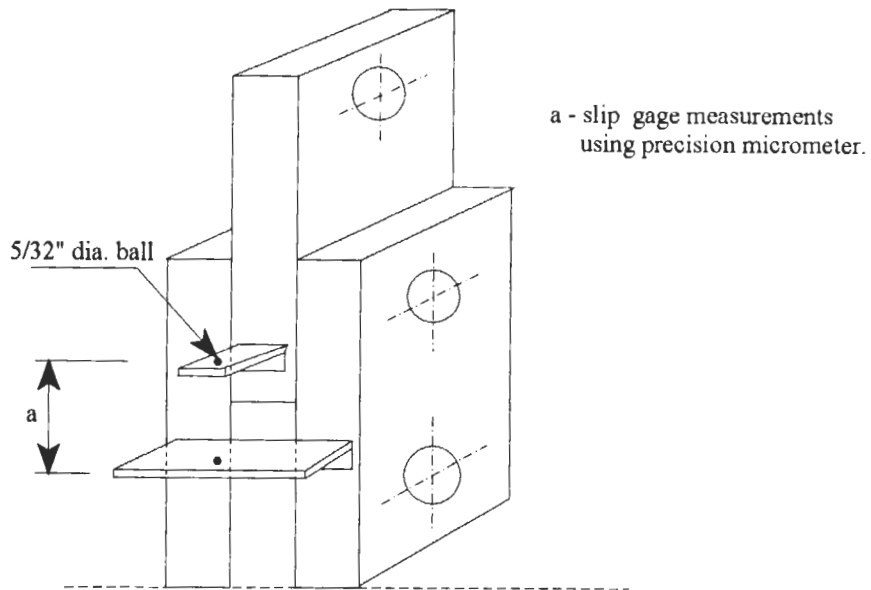

Figure 3. Slip Measurement

TEST RESULTS

Slip Coefficient Tests

A total of 30 tests were performed, 15 for standard holes, and 15 for oversize holes. Three identical specimens were tested for each coating thicknesses. They were based on nominal coatings of 5 mils, 15 mils and 20 mils. Six tests were also performed for nongalvanized clean mill-scale surfaces for comparison.

The slip coefficient k_s for an individual specimens was calculated as:

$$k_s = \frac{\text{load}}{(\text{number of shear planes}) (\text{clamping force})}$$

$$= \frac{P}{NF}$$

where,

k_s - slip coefficient;

P - slip load, kips;

N - number of slip planes, here N=2; and,

F - clamping force, equal to 39 kips for 7/8" A325 bolts.

In previous studies [14, 15], three different types of curves were observed for load-slip responses. These are shown in Figure 4. The slip load associated with each type is defined as:

Curve (a). The slip load is the maximum load, provided this maximum load occurs before a slip of 0.02 inch;

Curve (b). The slip load is the load at which the slip rate increases suddenly; and,

Curve (c). The slip load is the load corresponding to a slip of 0.02 inch. This definition applies when the load-slip response shows a gradual change;

The slip curve observed in this study is type (a) and is shown in Figure 5. The maximum load occurred before the slip reached 0.02 inch. Thus, the slip coefficient was calculated based on the maximum load.

A summary of the slip coefficient tests is presented in Table 4. The slip coefficients are given only to two decimal places because the authors feel that further refinement is unjustified due to the experimental scatter. The results are discussed in the following sections for the nongalvanized and galvanized specimens.

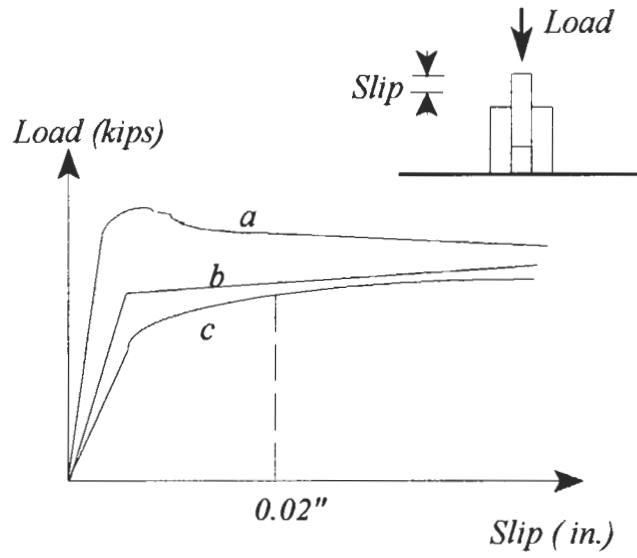

Figure 4. Definition of Slip Load

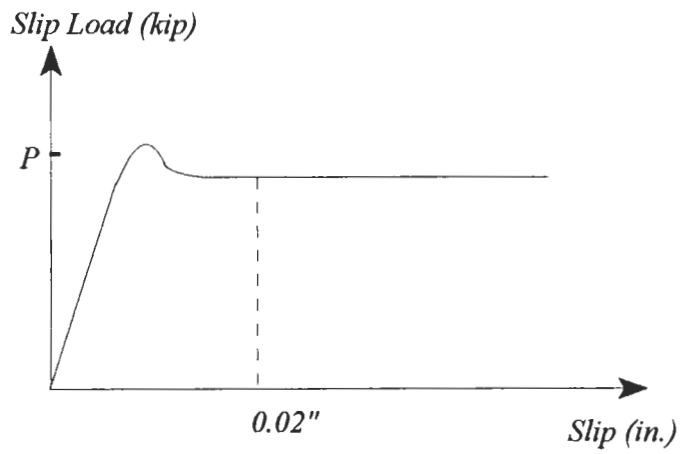

Figure 5. Test Curve of Load vs. Slip for Galvanized Surfaces

Table 4. Test Results of Slip Coefficient

Average Galvanized Coating Thickness for Faying Surface (mils)	Standard Hole Size (15/16 in. diameter)			Oversize Holes (1-1/8 in. diameter)			Summary - Standard and Oversize Holes		
	Mean Slip Coefficient	Number of Test	Standard Deviation	Mean Slip Coefficient	Number of Test	Standard Deviation	Mean Slip Coefficient	Standard Deviation	
0	0.44	3	0.10	0.56	3	0.04	0.50	0.09	
5.2	0.39	3	0.06	0.45	3	0.01	0.42	0.05	
16.1	0.41	5	0.04	0.43	5	0.05	0.42	0.04	
19.7	0.41	4	0.02	0.49	4	0.06	0.45	0.06	
Summary for All Coating Thicknesses			Slip Coefficient (average)	Standard Deviation			Total Number of Test		
			0.43	0.05			24		

Clean Mill-Scale Surfaces

In the six tests with clean mill scale surfaces, three were for standard hole sizes and three were for oversize hole sizes. For standard hole sizes, the average slip coefficient was 0.44 with a range from 0.34 to 0.53. For oversize holes, the mean was 0.56 with a range from 0.52 to 0.59. This is in contrast to other research findings. They found that with standard tightening techniques, such as load indicator washers, a 15% lower clamping force and consequently a lower slip load should be expected for oversize holes [6]. In this study the bolt tension was closely monitored during installation, and this produced the same bolt clamping force for both hole sizes. Thus the tests in this investigation did not produce any significant difference in slip coefficient for two hole sizes. It should be noted that the test results reported by other researchers (Fisher et al. 1974) exhibited a large scatter range for the slip coefficient. Based on the small number of tests in this study, it is concluded that the hole size does not produce significant differences in the slip coefficient.

For standard and oversize holes with clean-mill scale surfaces, the average slip coefficient was 0.50 with a standard deviation 0.09. This is higher than the value of 0.24 reported by Yura, et al., in 1981 for A588 steel [15]. Additionally, an average value of 0.34 was reported by Fisher and Struik for all types of steel. This was based on a total of 327 tests with a range from 0.20 to 0.58 for clean mill scale surface condition [6]. The results in this research are clearly at the high end of this range. In the bolt specifications, the mean slip coefficient, used to establish the allowable stress, was 0.33 for mill scale surfaces [1, 12]. The average slip coefficient of 0.50 in these tests was higher by approximately fifty percent. Nevertheless, the results in this study confirm that the design specification for clean mill-scale surfaces is conservative.

Galvanized Surfaces

Three different coating thicknesses were tested. The nominal thicknesses were 5 mils, 15 mils and 20 mils. As noted previously, the galvanizing process used in this research did not produce specimens with the nominal 10 mil thicknesses.

The test results are given in Table 4. As shown, the different coating thicknesses yielded approximately the same slip coefficient. The average value was 0.43 with a standard deviation of 0.05 for all coating thicknesses tested. The AASHTO Specification gives the slip coefficient for hot-dip galvanized, roughened surfaces as 0.40 [1], which is slightly lower than the test value 0.43 in this study. Previous research found that roughening by hand wire brushing produced an average slip coefficient of 0.37 where the coating thickness ranging from 2 to 5 mils [6]. In this study, with the coating ranging from 5 to 20 mils, a average slip coefficient was 0.43. Clearly, the coating thickness does not affect the slip resistance of the joint. Some previous researchers found that for other painting systems, such as organic zinc with epoxy, the slip coefficient decreases with an

increasing in coating thickness [7]. This is not the case for hot-dip galvanized coating, as found in this study.

Comparing the slip resistance of galvanized surfaces with the nongalvanized clean mill-scale surfaces, there is a significant reduction for galvanized surfaces. The slip coefficient is 0.50 for ungalvanized surfaces and 0.43 for galvanized surfaces. The same behavior is reported by other researchers [3, 4, 9, 11]. The low slip resistance of galvanized surfaces is caused by the presence of the soft zinc layer that tends to act as a lubricant between the contact surfaces [6].

After the tests were completed, the specimens were dismantled and examined. It was found that severe galling occurred around the hole under the washer. It was clear that the effective area for transfer of shear by friction between surfaces was concentrated in an annular ring underneath the washer around the hole.

Hole Size Effect

The comparison of slip coefficients between standard hole and oversize hole is shown in Figure 6. For standard hole sizes, the nominal 5-mil, 15-mil, and 20-mil surfaces yielded the slip coefficients of 0.39, 0.41, and 0.41 respectively; For oversize hole sizes, the slip coefficient yielded 0.42, 0.42, and 0.45 respectively. Clearly, the hole size does not influence the slip coefficient. Thus, oversize holes can be assumed to give similar results as for standard hole sizes.

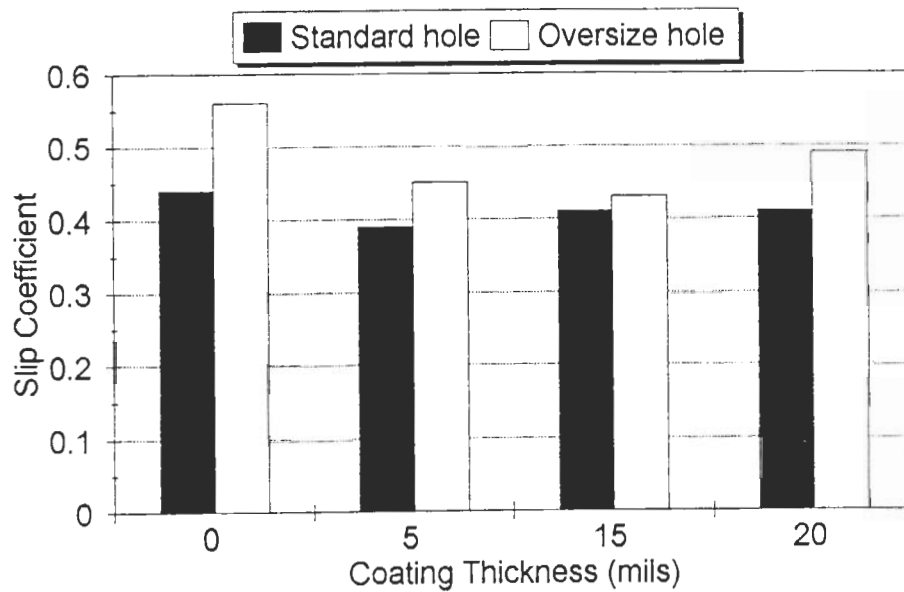

Figure 6. Slip Coefficient vs. Galvanized Coating Thickness

Relaxation of Clamping Force

The clamping force in the specimen was monitored continuously over a period of 42 days. The average losses in the clamping force for each coating thickness are given in Table 5. They are also plotted in Figures 7 and 8. For clean mill scale surfaces, the average loss in the initial clamping force was approximately 5.6%, which is consistent with the values reported by other researchers [6]. They had an average loss of 5% with a range between 2 to 11%.

For normal galvanized coating thickness (around 5 mils thick), the loss in the clamping force was found to be twice that for plain steel. However, when the coating thickness was increased to 20 mils, a loss of 19.9% was almost four times that for plain steel. This means the initial 39-kip clamping force is reduced to 31.2 kips. Even considering that the safety factor is 1.3, and that the normal installation technique yields a bolting force which is 13% higher than the minimum required a 39-kip clamping force [6], this amount of loss is high. The result is the clamping force may be below the minimum required for the high-strength connections after the losses. Clearly, the relaxation in the clamping force results in a decrease in the slip resistance. This effect must be incorporated into the design process to ensure safety.

It is noticed that ninety percent of losses occurred during the first week after assembly. During the remaining 35 days, the rate of change in bolt load decreased in an exponential manner. Even though there was still a relatively small drop, the clamping force was nearly stable after approximately the first 12 days.

With Figure 8, one can predict the loss of clamping force associated with a specific coating thickness. For example, when the galvanized coating thickness is about 11 mils thick, the amount of loss is about 15%. In other words, the remaining clamping force is just about 85% of its initial value.

Table 5. Relaxation of Clamping Force

Nominal Galvanized Coating Thickness (mils)	Loss of Clamping Force (%) After 42 days			Average Loss (%)
	Specimen 1	Specimen 2	Specimen	
0	4.5	6.3	5.9	5.6
5	14.4	11.0	14.3	12.4
10	14.6	17.2	17.3	15.3
15	16.2	19.1	16.3	19.6
20	18.4	20.6	16.3	19.9

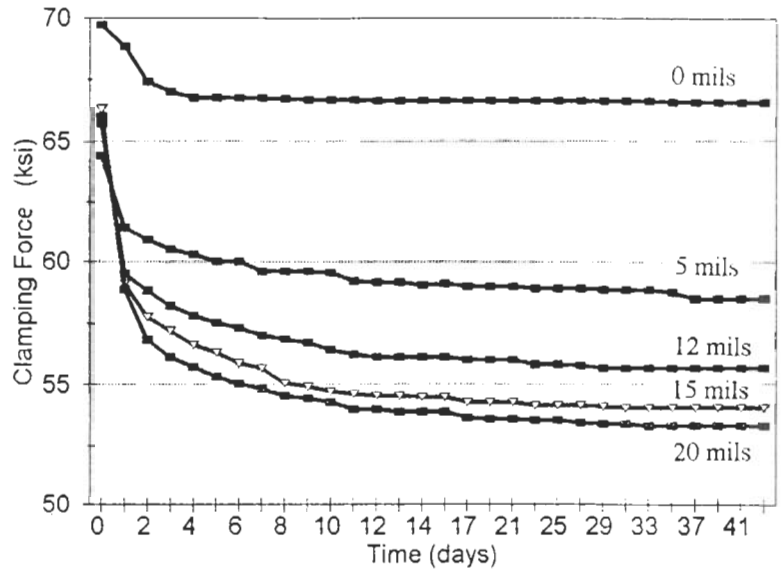

Figure 7. Typical Stress Relaxation Curves

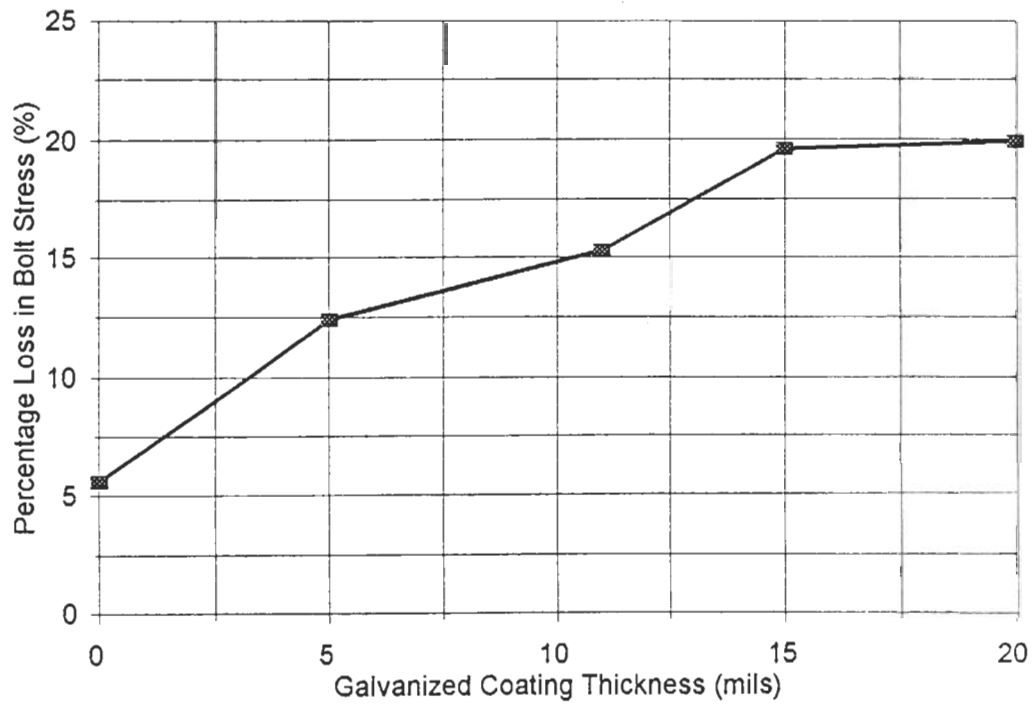

Figure 8. Stress Losses vs. Galvanizing Thickness

Relaxation Tests

The test results are shown in Table 6. For the nominal 5 mil coating, the clamping force was reduced by an average of 15.3% during the 21-day relaxation test. For nominal 15-mil and 20-mil coatings, the mean reduction in the clamping force was 17.2% and 18.4%, respectively. Clearly, the relaxation in the clamping force increases with increased coating thicknesses.

There is a reduction in slip resistance over time. After bolt relaxation for a 21-day period, the changes in the shear capacity vary with thicknesses, in inverse relation to the coating thicknesses. As shown in Table 6, for nongalvanized, plain steel surfaces, the average reduction in slip resistance is 21.2%. The average reduction is 19.5% for the nominal 5-mil thickness, 15.8% for the nominal 15-mil thickness and 8.0% for the nominal 20-mil thickness. The final shear capacity ranges from 24.0 kips to 29.2 kips for galvanized surfaces. As shown, there is no relation between this reduction and the coating thicknesses. With reduction of slip resistance over time, when compared to the initial capacity of nongalvanized specimens, it is difficult to reach a final conclusion that the thick coating will reduce the slip resistance of the joints more than the thin coating. However, the creep tests discussed in the next section, show that the reduction in the slip resistance over time clearly influences the slip behavior. With increased coating thicknesses, slippage increases.

Table 6. Comparison of Slip Load With and Without Relaxation

Bolt No.	Nominal Coating Thickness (mils)	Actual Faying Surfaces (mils)	Clamping Force			Bolt Shear Capacity (kips)			
			Initial Value (kips)	After 21 days (kips)	Mean Loss (%)	Mean Before Relax.	After Relax.	Mean After Relax.	% Reduction Due to Relax.
1	0	0	37.4	36.6	1.6%	39.6	35.1	31.2	21.2%
3	0	0	38.9	38.4			32.1		
1	0	0	38.7	38.2			26.3		
4	5	5.2-5.3 5.0-4.9	38.3	32.8	15.3%	29.8	25.5	24.0	19.5%
6	5	5.0-5.2 4.9-4.9	38.7	32.4			22.5		
5	10	11.4-11.9 11.8-11.4	39.0	33.3	16.3%	-----	32.2	29.2	-----
6	10	13.3-13.9 13.9-14.1	38.3	31.7			32.0		
4	10	12.1-12.5 13.1-15.5	38.0	31.5			23.4		
7	15	16.5-16.3 16.5-16.5	38.9	32.6	17.2%	31.7	26.2	26.7	15.8%
9	15	15.9-16.5 15.0-15.9	38.0	30.8			30.6		
5	15	15.9-14.8 14.6-14.9	38.7	32.4			23.2		
8	20	19.4-19.3 19.4-19.5	37.2	30.4	18.4%	31.2	26.9	28.7	8.0%
10	20	19.0-20.0 20.0-19.5	38.1	30.2			29.2		
7	20	20.1-20.0 19.9-20.0	38.1	31.9			29.9		

NOTE: Due to a galvanizing error, 10-mil specimens resulted only for relaxation tests.

Creep Behavior

The creep behavior of specimens with different coating thicknesses was monitored over a period of 42 days. The plot of total slip versus time was made for all tests. In order to obtain a clearer understanding of the slip behavior associated with the varying coating thickness, all test results are graphed in Figures 9 through 13.

For clean mill scale surfaces, as mentioned previously, the average slip coefficient was 0.50. This was higher than the AASHTO Specification value of 0.33 by approximately fifty percent. Thus, the design specification for clean mill scale surfaces is on the safe side. Even under loading higher than its design service loading, there was no slippage detected during the 42-day test period for clean mill-scale surface.

For nominal coating thicknesses equal to 5 mils and 10 mils, no slippages were detected during the 42-day test period. For nominal 15-mil and 20-mil thicknesses, the average slippages were 0.0013 in. and 0.0018 in. respectively. For 15-mil and 20-mil thick coatings, the average slippage was approximately 0.0016 in. This indicated that the slip resistance for thick galvanized coatings had been reduced as a result of loss in the bolt clamping force. The extreme result would be that the joint slips into bearing. This is not permitted for high-strength slip critical joints.

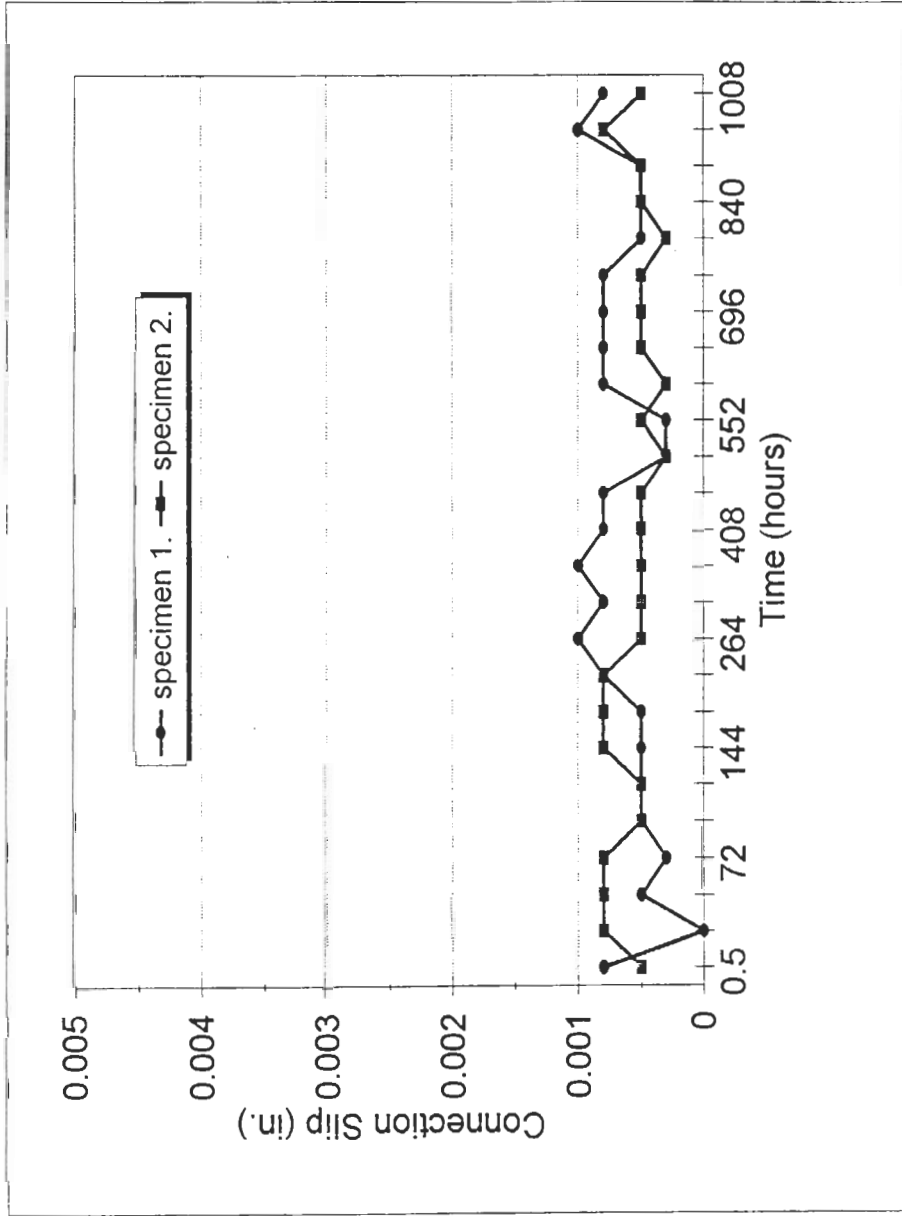

Figure 9. Creep Behavior for Plain Steel (Base for Comparison)

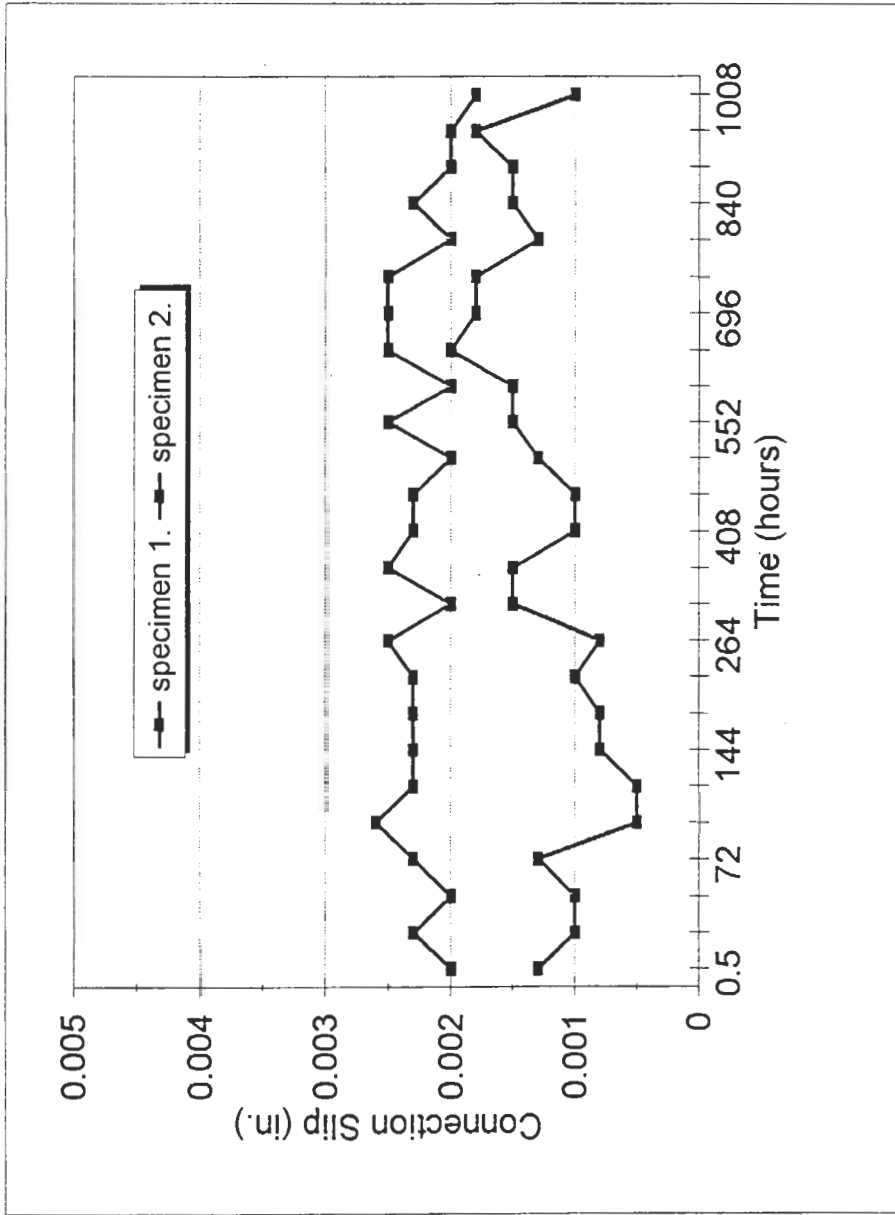

Figure 10. Creep Behavior for Galvanized Surfaces with 5-mil Thick Coating

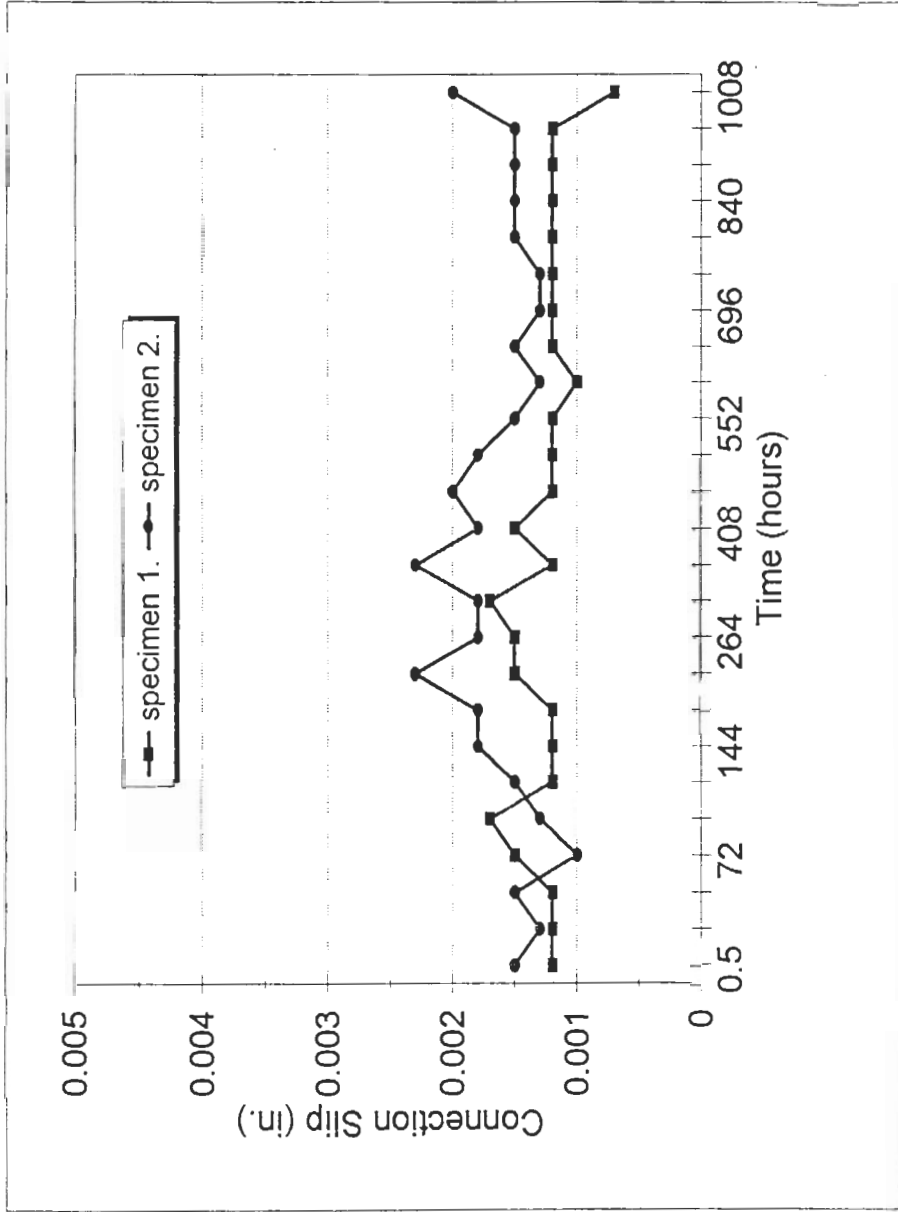

Figure 11. Creep Behavior for Galvanized Surfaces with 10-mil Thick Coating

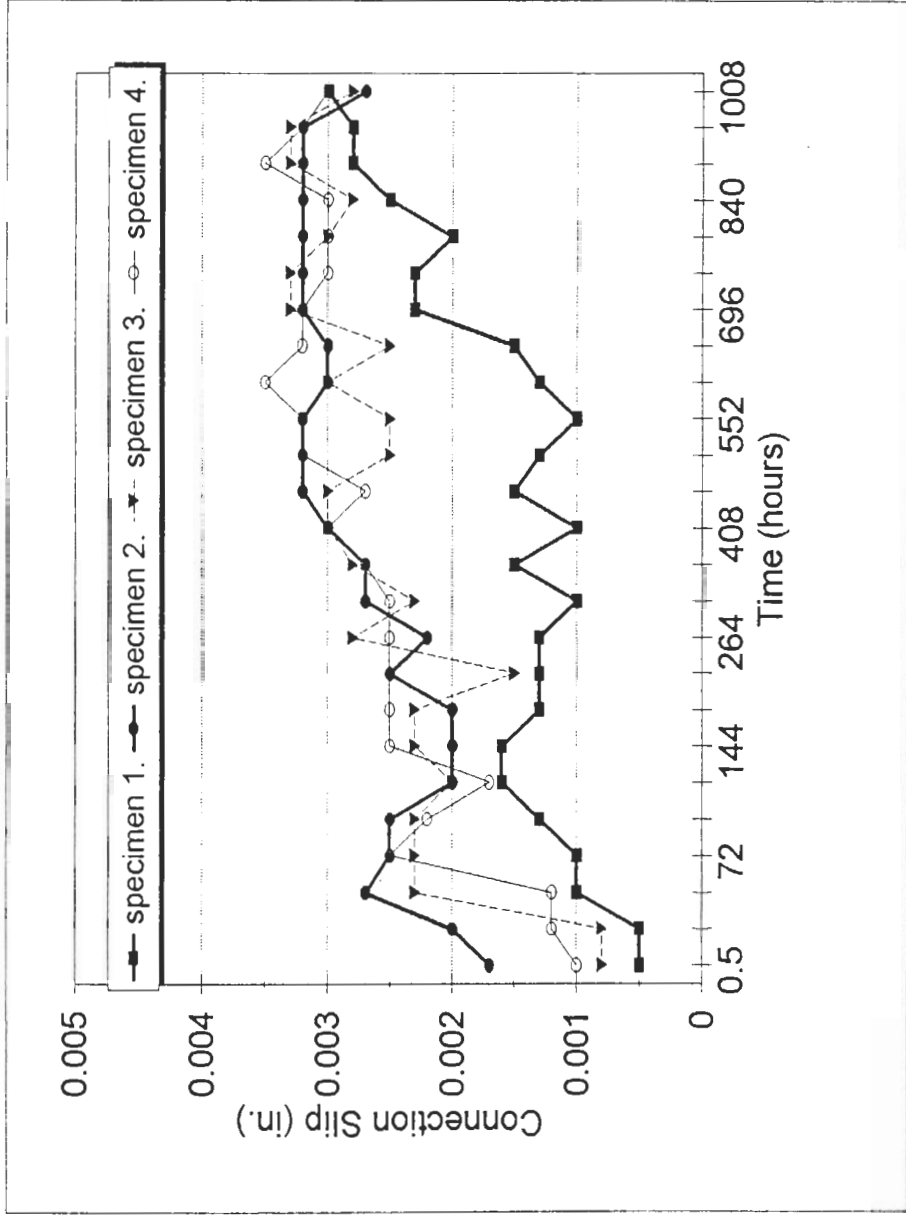

Figure 12. Creep Behavior for Galvanized Surfaces with 15-mil Thick Coating

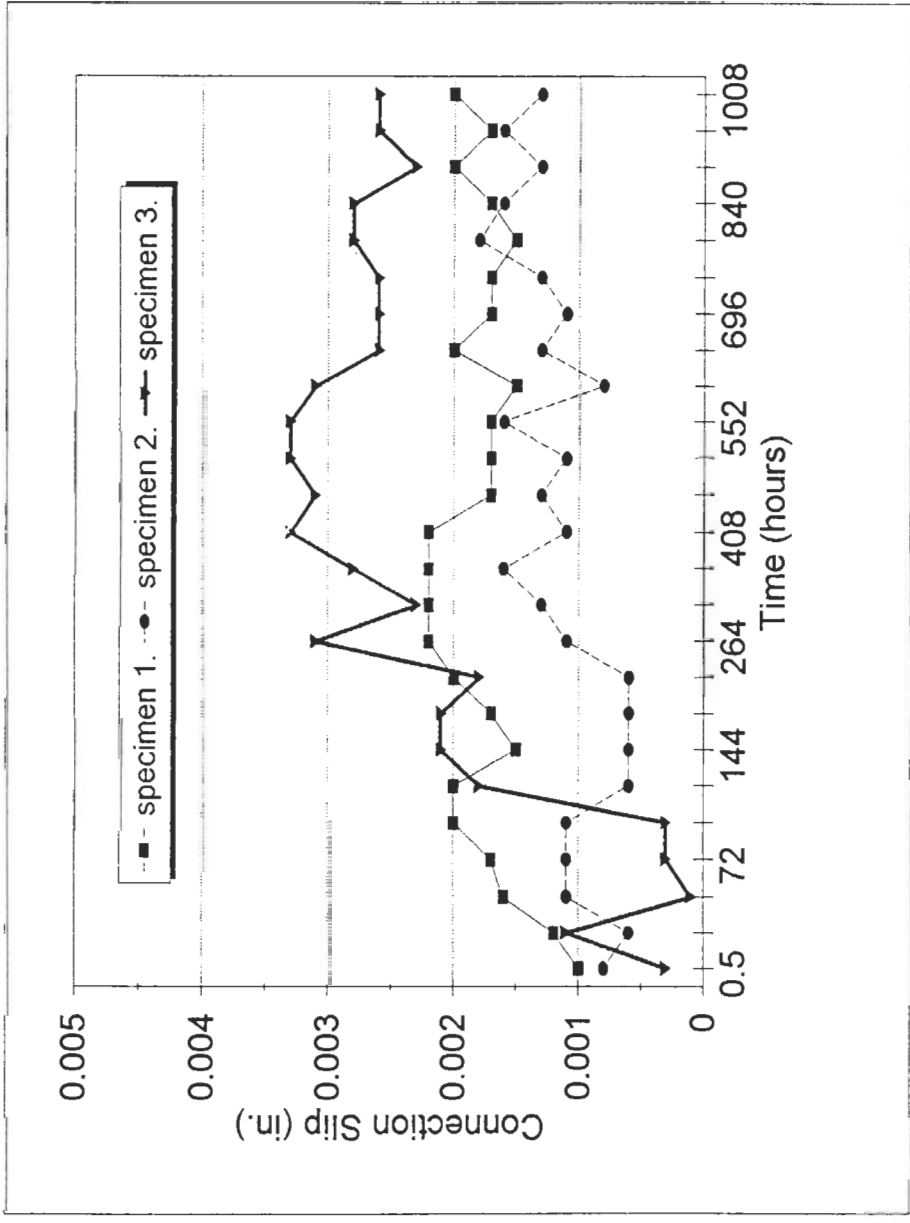

Figure 13. Creep Behavior for Galvanized Surfaces with 20-mil Thick Coating

DESIGN RECOMMENDATIONS

The test results show that increasing the coating thickness up to 20 mils for both standard size and oversize holes does not significantly alter the slip coefficient. However, the loss of clamping force over time due to the creep in the coating significantly reduces the slip resistance of the joint. As shown in the creep tests subjected to sustained loading, the performance of the connection for both nominal 5-mil and nominal 10-mil thicknesses was within acceptable limits. The slippage detected during the 42 days test period resulted an average 15.3% loss in the clamping force for the joints with the nominal 10-mil thick coating. However, for the nominal 15-mil and 20-mil thick coatings, the behavior was not satisfactory. There was an average 19.9% loss in the clamping force for the nominal 20-mil thick coatings and an average slip of 0.0013 in. was recorded within the test period. It is clear that the slip resistance of the joints is reduced for the thicker coating. With the reduction of slip resistance, there is an increased likelihood that the joint may slip into bearing under service conditions.

It is recommended that galvanized coating thicknesses should not be greater than 10 mils thick. If a thicker galvanized coating is used, the associated design allowable stresses must be decreased to account for the effect of loss of clamping force due to the creep of the galvanizing layer.

In the 1992, 15th edition of AASHTO Specification [1], the allowable bolt shear stress of 20 ksi (for standard hole size) and 17 ksi (for oversize hole) for galvanized surfaces was based on a slip coefficient of $K_s=0.40$. This is based on a minimum specified clamping force 39 kips and a factor of safety 1.3.

For galvanized coating thickness between 10 mils to 20 mils, the slip coefficient may be based on the standard value of $K_s=0.40$ as shown by the results of this study. The factor of safety of 1.3 is still applicable for these galvanizing thicknesses. However, it is necessary to account for the decrease in the clamping force over time. The maximum reduction in the clamping force was 19.9%. Thus, it is recommended that the clamping force be reduced by 20%. The slip load is then equal to the 39 kips clamping force times the slip coefficient 0.40, with a 80% reduction. Thus, the ultimate load P_μ should be:

$$P_\mu = 0.80 \times K_s \times N$$

where, K_s --- slip coefficient; and,

N --- clamping force, 39 kips minimum required.

Thus,

$$P_\mu = 0.80 \times 0.4 \times 39 \text{ kips} = 12.48 \text{ kips (load)} \quad \text{and,}$$

$$\text{Ultimate stress} = \frac{12.48}{0.601 \text{ inch}^2} = 20.77 \text{ ksi}$$

With a factor of safety of 1.3, this becomes:

$$\text{allowable shear stress} = \frac{20.77}{1.3} = 15.97 \text{ ksi} \approx 16.0 \text{ ksi}.$$

Therefore, the allowable design stress should be 16 ksi (110 Mpa) for A325 bolts, installed in standard size holes when the galvanized coating is thicker than 10 mils.

As mentioned previously, when using standard bolt installation techniques, a lower clamping force is expected for oversize holes [6]. Thus, an additional 15% deduction should be applied for oversize holes [6]. The allowable stress is then 0.85 times 16 ksi, which yields 13.6 ksi (93.8 Mpa).

When the galvanized coating is 20 mils thick, the clamping force is reduced by about 20%. This results in an unacceptable slip resistance. Therefore, under no circumstances, should galvanized surfaces with coatings greater than 18 mils be used. Note that this coating limitation is 2-mil thinner than the test specimens. This is based on Reference 14, which allows for a 2-mil variation in coatings. This limitation assures that the coating buildup does not jeopardize the connection's performance.

CONCLUSIONS

When hot-dip galvanizing with thicknesses in the range of 13 mils was used in a recent bridge application, engineers were concerned about the potential loss in the clamping force. In this study, tests were conducted on high-strength bolted connections to determine how much the shear capacity is reduced by relaxation in the clamping force. Coating thicknesses up to 20 mils thick were tested. The following are the main conclusions for this study:

1. The effect of hole size on the slip resistance is insignificant with respect to the short term static behavior for friction-type joints with galvanized surfaces.
2. For galvanizing up to 10 mils thick, the AASHTO Bridge Specification is applicable. Both the design slip coefficient and the allowable stresses are acceptable.
3. It is not recommended that galvanized thickness greater than 10 mils be used on bridge structures, since there is a considerable reduction in the slip resistance due to the losses in the clamping force. If thicknesses greater than 10 mils are used, the corresponding design allowable stresses should be reduced accordingly. The design allowable stress should be 16.0 ksi for standard hole sizes, and 13.6 ksi for oversize hole sizes when the coating is greater than 10 mils thick.

4. Under no circumstances, should a galvanized coating thickness greater than 18 mils be used.

REFERENCES

1. American Association of State Highway and Transportation Officials (AASHTO) (1992). "Standard Specification for Highway Bridges." Fifteenth Edition, Washington, D. C.
2. Bickford, John H. (1990). "An Introduction to the Design and Behavior of Bolted Joints." Second Edition, Marcel Dekker, Inc., pp. 272-273.
3. Birkemore, P. C. and Herrschaft, D. C. (1970). "Bolted Galvanized Bridges: Engineering Acceptance Near." Civil Engineering, Vol. 40, No. 4, April, pp.42-46.
4. Brookhart, G. C., Siddiqi, I. H. and Vasarhelyi, D. D. (1968). "Surface Treatment of High Strength Bolted Joints." Journal of the Structural Division, ASCE, Vol. 94, No. ST 3, Paper 5851, pp. 671-681.
5. Donald, Eric (1979). "Bleeding Structures - the Detection of Fatigue in Engineering Elements." Aircraft Engineering, Vol. 51, No. 1, January, pp. 25-29
6. Fisher, J. W., Struik, J. H. and Kulak, G. L. (1974). "Guide To Design Criteria for Bolted and Riveted Joints." John Wiley & Sons Inc., New York, New York.
7. Frank, K. H. and Yura, J. A. (1981). "An Experimental Study of Bolted Shear Connections." FHWA Final Report, FHWA/RD-81/148.
8. Lobb, Verl and Stoller, Floyd (1971). "Bolted Joints under Sustained Loadings." Journal of Structural Division, ASCE, Vol. 97, No. ST3, Proceedings paper 7996, pp. 905-933.
9. Munse, W. H. and Birkemore, P. C. (1969). "High-strength Bolting of Galvanized Connections." The Australian Institute of Steel Construction and the Australian Zinc Development Association, Sydney-Melbourne, Australia.
10. Nanninga, Mark Gary (1978). "Creep Behavior of Friction Type Joints with Coated Faying Surfaces." M. S. thesis, University of Texas at Austin, Texas.

11. Office of Research and Experiments of the International Union of Railways (ORE) (1967). "Coefficient of Friction of Faying Surfaces Subjected to Various Corrosion Protective Treatments." Report 2, ORE, Utrecht, The Netherlands.
12. Research Council on Riveted and Bolted Structural Joints (1976). "Specification for Structural Joints Using ASTM A325 or A490 Bolts." American Institute of Steel Construction.
13. Yang, Jun (1997). "Relaxation in High-strength Bolted Connections with Galvanized Steel." M.S. thesis, University of Connecticut, Storrs, Connecticut.
14. Yura, J. A. And Frank, K. H. (1985). "Testing Method to Determine the Slip Coefficient for Coatings Used in Bolted Joints." Engineering Journal, 3rd Quarter, pp. 151 - 155.
15. Yura, J. A., Frank, K. H. and Cayes, L. (1981). "Friction-type Bolted Connections with A588 Weathering Steel." FHWA, Final Report, FHWA/RD-81/147.

APPENDIX

Table Appendix 1. Slip Coefficient Test Results

Bolt No.	Average Coating Thickness (mils)	Clamping Force		Slip Load P (kips)	Slip Coefficient	Average	Std. Deviation	Note
		(ksi)	(kips)					
1	0	67.2	38.5	35.0	0.45	0.44	0.1	Std. Hole
1	0	67.4	38.6	40.5	0.53			
3	0	66.8	38.9	26.5	0.34			
1	0	67.8	38.9	44.2	0.57	0.56	0.04	oversize hole
1	0	67.3	38.6	46.0	0.59			
1	0	67.5	38.7	40.0	0.52			
2	5.3-5.4 5.2-5.2	67.2	38.8	27.7	0.36	0.39	0.06	Std hole
2	5.0-5.0 5.0-5.0	66.9	38.7	34.6	0.45			
2	5.4-5.4 5.3-5.3	66.7	38.5	27.2	0.35			
2	14.8-14.7 15.8-15.7	66.6	38.5	33.6	0.44	0.41	0.04	Std hole
2	15.5-15.3 14.5-15.0	66.6	38.5	27.4	0.36			
2	16.0-16.3 16.4-16.5	65.5	37.9	29.8	0.39			
2	16.3-16.4 17.0-16.8	65.5	37.9	31.4	0.42			

Table Appendix 1. Continued

Bolt No.	Average Coating Thickness (mils)	Clamping Force		Slip Load P (kip)	Slip Coefficient	Average	Std. Deviation	Note
		(ksi)	(kips)					
2	18.3-18.5 18.1-18.3	65.7	38.0	31.2	0.41	0.41	0.02	std hole
2	19.8-20.0 19.5-19.5	66.2	38.3	32.2	0.42			
2	19.5-19.3 20.0-19.8	66.5	38.5	29.0	0.38			
2	20.8-20.5 19.8-19.8	65.5	37.9	32.2	0.43			
2	5.7-5.6 5.4-5.7	66.5	38.5	35.3	0.46	0.45	0.01	oversize hole
2	5.1-5.0 5.1-5.0	66.7	38.6	35.1	0.46			
2	5.6-5.5 5.5-5.4	64.5	37.3	33.0	0.44			
2	17.6-17.5 17.5-17.3	65.1	37.7	34.2	0.45	0.43	0.05	oversize hole
2	15.0-15.0 16.0-16.0	66.6	38.6	36.4	0.47			
2	17.8-17.5 16.8-17.8	63.4	37.0	34.9	0.47			
2	20.3-20.0 20.0-21.0	64.5	37.3	40.0	0.54	0.49	0.06	oversize hole
2	20.4-20.0 20.0-20.3	64.7	37.5	31.7	0.42			
2	20.8-20.0 20.0-20.8	65.6	38.0	39.7	0.52			
2	18.5-19.0 19.0-19.3	65.3	37.8	34.8	0.46			

Table Appendix 2. Test Results for Creep Tests

Specimen No.	Average Coating Thickness (mils)	Slippage after 42 days (in.)	Average Slippage (in.)	Standard Deviation
01	0	0	0	0
11	0	0		
05	5.4-5.3 5.1-5.0	0	0	0
09	5.0-5.1 5.2-5.3	0		
12	12.1-12.1 12.3-13.3	0.0005	0.00025	0.0003
04	12.4-12.6 12.4-12.3	0		
08	13.0-15.7 15.0-15.3	0.002	0.0018	0.0006
10	16.5-16.4 16.1-16.6	0.002		
06	17.5-16.8 17.5-17.1	0.001		
07	17.3-17.4 16.8-17.0	0.0025		
13	20.0-19.8 20.0-20.1	0.001	0.0013	0.0009
14	20.5-19.5 19.8-20.0	0.0005		
15	19.6-20.0 20.0-19.0	0.0023		